



INSTRUCTION MANUAL



Guillotine Pipe Cutter

For PE pipes 63-225 mm

Table of contents

1.	Safety	4
1.1	General safety guidelines for tools	4
1.2	Specific safety guidelines for the Guillotine Pipe Cutter	5
1.3	Explanation of symbols	5
1.3.1	General symbols	5
1.3.2	Mandatory symbols	5
1.3.3	Prohibition symbols	5
1.3.4	Warning symbols.....	6
2.	Introduction	7
2.1	Scope of application	7
2.2	Maintenance and service.....	7
2.3	Handling and maintenance.....	7
2.4	Disposal	7
3.	Scope of delivery	8
4.	Technical data	8
5.	Overview and spare parts	9
6.	Cutting pipes	10
6.1	Preparation and adjustment.....	10
6.2	Fixing the Guillotine Pipe Cutter.....	12
6.3	Inserting and cutting a pipe	13
6.4	End of the cutting procedure	15
7.	Service	16
8.	Declaration of conformity 	17

1. Safety

The basic condition for safely handling and a hassle-free operation of the product is the knowledge about the fundamental safety guidelines and safety regulations. This instruction manual contains important information on how to handle the tool safely. Everyone working with this equipment shall read and understand these instructions. These instructions shall be read and implemented in accordance with the relevant standards, workplace health and safety legislation, installation instructions, Codes of Practice and technical connection guideline in force in your country.

1.1 General safety guidelines for tools

- a) Read and make sure you understand all safety guidelines and instructions. Failure to follow the safety guidelines and instructions can lead to electric shock, fire and/or serious injury.
- b) Keep these safety guidelines and instructions for future use.

1) Safety in the work area

- a) Keep your work area clean and well lit. Working in cluttered or dark areas can easily lead to accidents. Prevent the tool from unintentional movement or dropping and assume a secure foothold.

2) Personal safety

- a) Stay alert! Watch what you are doing and use common sense when operating a tool.
- b) Use personal protective equipment and always wear eye protection. The use of protective equipment such as a dust mask, non-skid safety shoes, a hard hat or hearing protection, depending on the tool and its use will reduce personal injuries.
- c) Wear appropriate clothing. Do not wear loose clothing or jewellery. Keep your hair, clothing and gloves away from moving parts. Loose clothes, jewellery or long hair can get caught by moving parts.
- d) Make sure that all users of the tool have read this instruction manual completely and understood it and that they are trained accordingly.

3) Tool usage and care

- a) Keep your tools clean. Follow the servicing instructions and the instructions for changing the tools. Keep oil and grease away from the handles.
- b) Care for your tools. Check for misalignment or binding of moving parts, breakage of parts and any other condition that may affect the operation of the tools. If damaged, have the tool repaired before use. Many accidents are caused by poorly maintained tools.
- c) Use the tool, accessories etc. in accordance with these instructions. Take the working conditions and the work to be performed into account. The use of the tool for applications differing from the application scope could result in a hazardous situation.
- d) Make sure, that the serial number and the type plate are not removed from the tool.

4) Service

- a) Have your tool repaired only by a qualified technician with identical replacement parts. This will ensure that the safety of the tool is maintained.

1.2 Specific safety guidelines for the Guillotine Pipe Cutter

1) Personal safety

- a) The operator must have a safe foothold.
- b) Working overhead in areas not completely visible (e.g. under a pipe) is prohibited.
- c) Pipes and other workpieces must be firmly clamped or fixed. Poorly clamped or fixed workpieces may hurt you or affect your safe foothold.
- d) It is imperative that you follow all national and international standards and guidelines in force for cutting pipes.
- e) Do not transport the tool on your own. Get some help when moving or transporting the tool. The high weight of the tool can lead to injuries when lifting it.
- f) Execute all preparations and the setup of the tool before beginning to cut the pipe.
- g) Never touch the cutting blade with bare hands. Severy injuries could result if you accidently or abruptly touch the blade. Wear cut-resistant gloves.
- h) Never work or manipulate anything under the cutting blade. Severy injuries could result if you accidently or abruptly touch the blade. Wear cut-resistant gloves.

1.3 Explanation of symbols

This instruction manual can make use of the following symbols:

1.3.1 General symbols



This symbol indicates a general advice.

These advices describe recommended courses of action to enable the user to perform steps quicker and safer. The symbol can also underline certain required precondition or mean that the user must follow certain mandatory steps.

1.3.2 Mandatory symbols



Observe the instructions!

Read the provided documentation thoroughly to prevent applications errors and to work safer and according to the scope of application with the respective product. All users of the product must thoroughly read and understand the provided documentation prior to use.

Reading the documentation thoroughly and completely helps preventing accidents due to improper use and eases the work with the product.

1.3.3 Prohibition symbols



General prohibition symbol!

There is a high risk of injury. Observe the detailed description of the prohibition.

Failure to comply with this prohibition can lead to injury or damage to devices, machines or tools.

1.3.4 Warning symbols



General warning symbol!

This symbol warns of a potentially dangerous situation.

Failure to comply with the warning and advice can lead to injury or damage to goods.



Warning: Sharp elements!

This symbol warns of a potential risk of injury due to pointy and/or sharp items like needles or blades.

Failure to comply with the warning and advice can lead to stabbing or cutting injuries to the hands or other body parts.

2. Introduction

2.1 Scope of application

The Guillotine Pipe Cutters 63-225 mm are solely meant for cutting PE-pipes in the dimensions range 63-225mm (SDR11). The cutting of the pipe is done by a special cutting blade that is connected to a threaded bar and pushed into the pipe by turning a crankshaft.



Intended use

It is not allowed to use the tool for any application not covered by the above stated terms. Modifying the tool without consulting the manufacturer is forbidden and shall be considered as improper use.

The manufacturer is not liable for use of the Rotational Scraper Tool that falls outside its application scope!

2.2 Maintenance and service

Should the tool fail despite the great care taken in manufacturing and testing it, the necessary repairs should only be carried out by an after-sales service centre authorised by the manufacturer.

Please note that the product is a technically demanding machine for field application. In accordance to the applicable standards the tool is subject to periodical maintenance. The maintenance interval is 12 months, with heavy use shorter intervals are recommended.

During maintenance, the tool will be upgraded to the current technical standard of our devices and you get a 3-month guarantee on function for the maintained tool.

The maintenance and the related checks are important for your safety and the continuous working reliability and safety of the tool. Therefore, the maintenance and all necessary repairs, have to be carried out by the manufacturer or an authorised service point.

For further information about our after-sales service centres please contact:

PF-Schweißtechnologie GmbH
Karl-Bröger-Str.10
DE-36304 Alsfeld
Germany

Tel.: +49-6631-9652-0
Fax: +49-6631-9652-52
E-Mail: info@pfs-gmbh.com
Web: www.pfs-gmbh.com

In all correspondence, please provide the serial number (S/N) as shown on the type plate of the tool.

2.3 Handling and maintenance

To achieve an optimum work results the tool has to be handled with care and maintained frequently. Pollution by sand and dirt has to be avoided or, if necessary, removed with a soft cloth or a Q-tip.

A regular check of the Guillotine Pipe Cutter, depending on the frequency of application, should be performed every 6 to 12 months by an authorised service station.

2.4 Disposal

The Guillotine Pipe Cutter 63-225 mm must be disposed of in an environment-friendly way sorted by materials.

3. Scope of delivery

4_4400_010	Guillotine Pipe Cutter 63-225 mm		Enclosed
	1 x	Instruction manual	EN206
	2 x	Crank shaft	1_4400_008
	1 x	Blade protector	1_4400_015
	1 x	Packaging box	1_2800_059

4. Technical data

4_4400_010		Guillotine Pipe Cutter 63-225 mm	
General			
Suitable for pipes made of		PE	
For pipe dimensions	[mm]	63-225	
For pipe dimensions	[CTS]	-	
For pipe dimensions	[IPS]	3-8	
For pipe dimensions	[DIPS]	3-6	
Maximum SDR		11	
Dimensions, weights and packaging			
Product dimensions L x W x H	[mm]	1050 x 420 x 200	
Product weight	[kg]	26	
Packaging dimensions L x W x H	[mm]	980 x 550 x 290	
Packaging material		Wood	
Packaging type		Box	
Packaging weight	[kg]	20.5	
Transport weight	[kg]	46.5	

The given technical information is valid for the standard setup of the tool. Depending on the ordered setup there may be variations.

5. Overview and spare parts

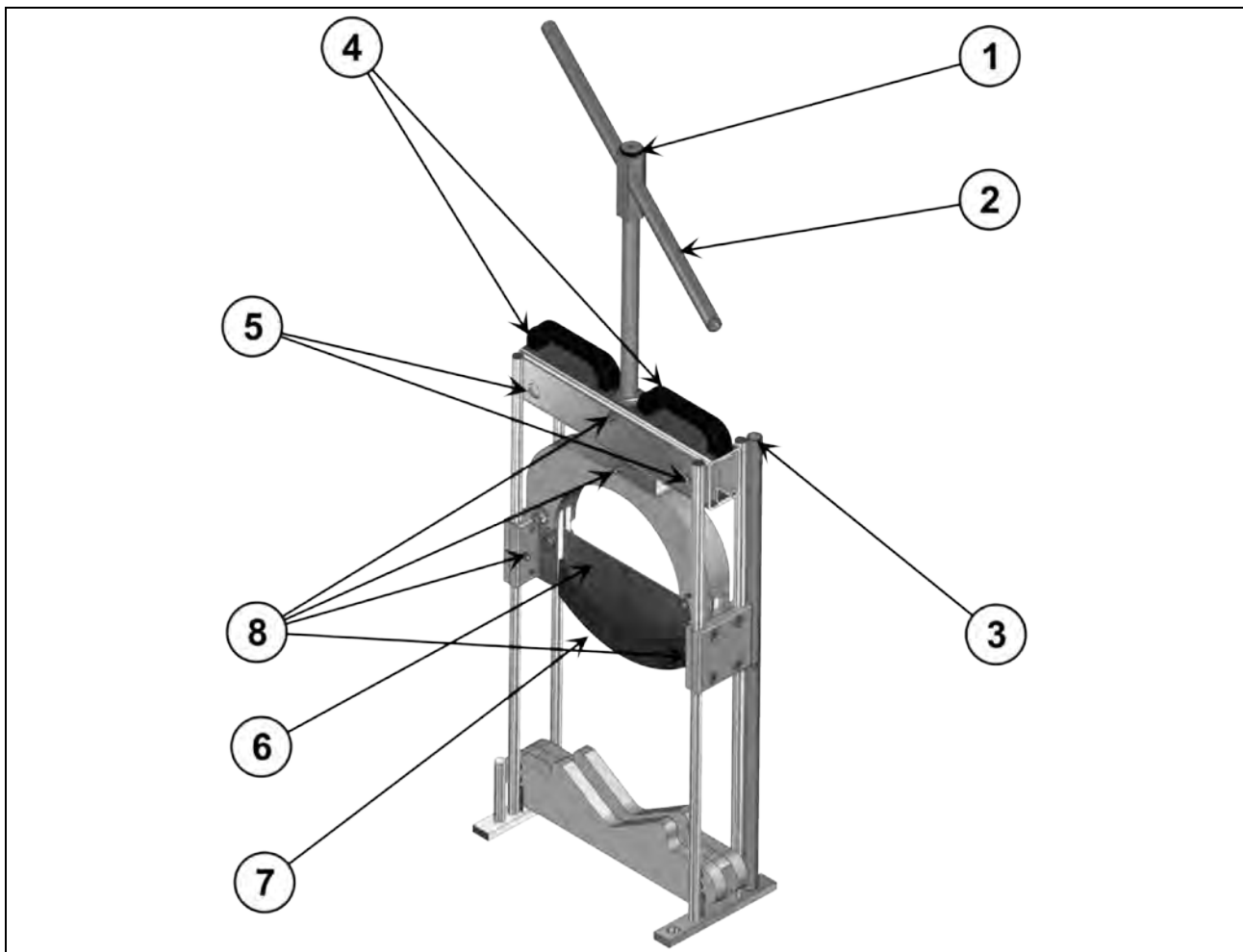

Object in graphic	Description	Code
1	Knurled nut	2_4400_006
2	Crank shaft	1_4400_008
3	Crank shaft	1_4400_008
4	Carrying handles	1_2400_007
5	Seat for the crankshaft for holding-up	
6	Cutting blade complete	2_4400_004
7	Blade protector	1_4400_015
8	Grease nipple	

6. Cutting pipes





Note

The numbers in brackets refer to the respective overview in chapter 5 "Overview and spare parts".

6.1 Preparation and adjustment

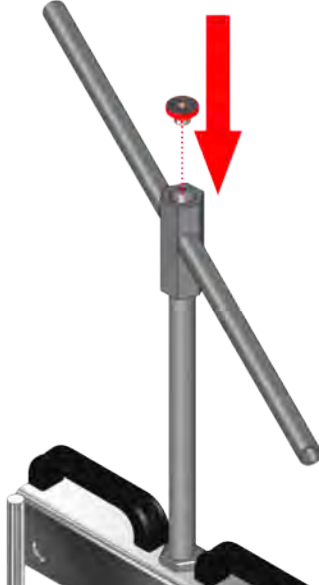
Step	Action
1	Cleaning the pipe
1.1	Use a clean cloth free of dirt and grease to remove mud, sand and dirt from the pipe surface. Make sure that the pipe is free from foreign objects. If necessary additionally use certified pipe cleaner.
2	Installing the crankshaft
2.1	Insert one of the crankshafts into the opening in the hexagon piece and lock it in place with the screw like shown in the following pictures.



Step	Action
3 3.1	<p data-bbox="268 219 651 248">Removing the blade protector</p> <p data-bbox="268 271 1426 300">Pull off the blade protector. Be extra careful. There is a risk of cutting injuries by the cutting blade.</p> 



Warning: Sharp elements!

After the removal of the blade protector there is a high risk of cutting injuries in the area around the cutting blade and its tip. If possible, avoid working close to the exposed cutting blade. Always wear cut-proof gloves to minimize the risk of dangerous cutting injuries.

Failure to comply with the warning and advice can lead to stabbing or cutting injuries to the hands or other body parts.

6.2 Fixing the Guillotine Pipe Cutter

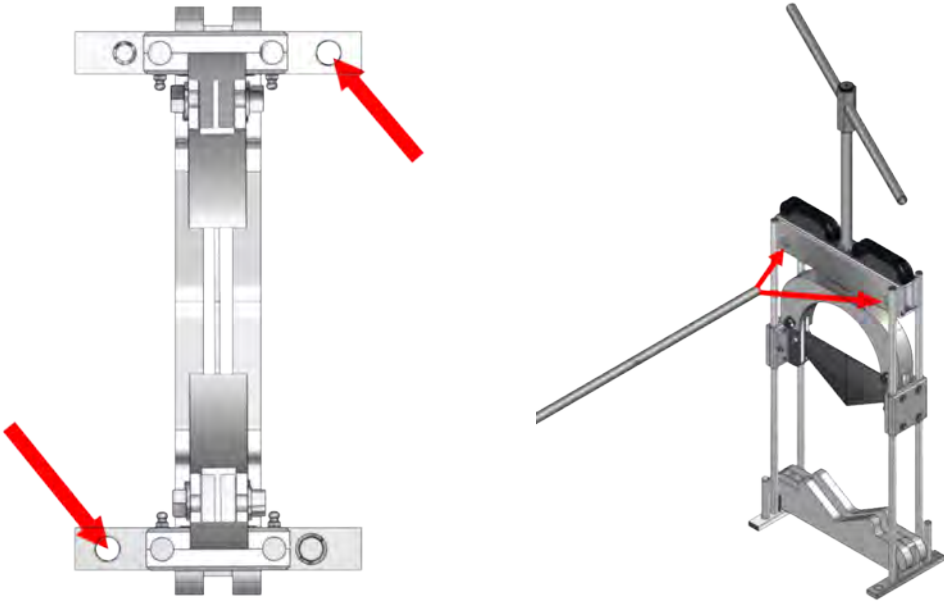
Step	Action
4 4.1	<p data-bbox="268 286 518 320">Fixing / positioning</p> <p data-bbox="268 338 1406 488">The force necessary to cut a pipe can be quite high depending on the pipe dimension and SDR. To support the user, the Guillotine Pipe Cutter has two openings in the feet to fix in place by inserting ground spikes. Other than that, you can counter the cutting force by using the second crankshaft. This can be inserted into one of the holes by a second person to hold the Guillotine Pipe Cutter while the first person screws the cutting blade into the pipe.</p> 

6.3 Inserting and cutting a pipe



Warning: Sharp elements!

Always wear cut-proof gloves when working close to the cutting blade to minimize the risk of cutting injuries.

Failure to comply with the warning and advice can lead to stabbing or cutting injuries to the hands or other body parts.



Attention!



Check the pipes before cutting them. The pipe must be free from foreign objects!

Step	Action
5 5.1	<p data-bbox="268 622 791 658">Position the pipe under the cutting blade</p> <p data-bbox="268 674 1386 739">Position the pipe resp. the Guillotine Pipe Cutter under the cutting blade so that the cut can be made at the desired point.</p> 



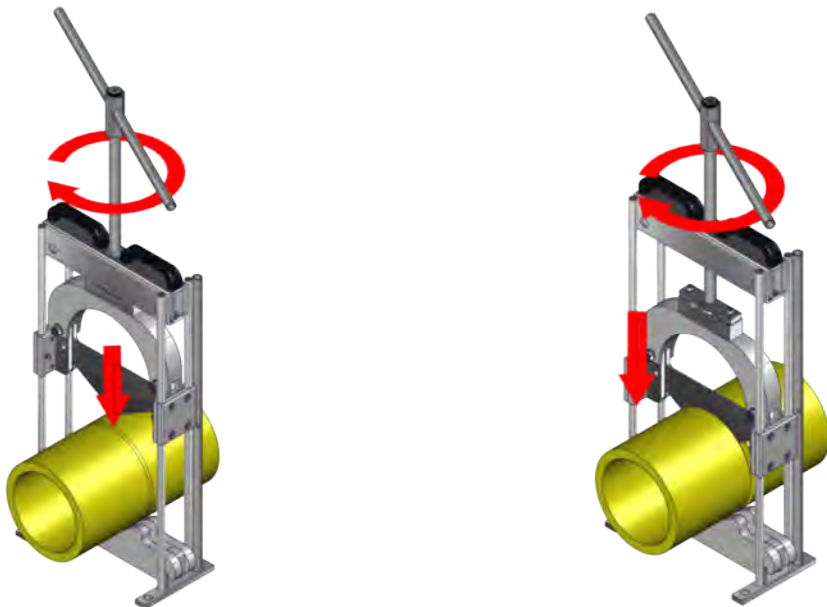

Attention!

Take care to position the tool on an even surface and that it cannot tilt or slip. Do not lift and move the tool on your own. Use hoisting equipment or a second person to help moving the tool.

Step	Action
6	Cutting procedure
6.1	Turn the crankshaft to lower the cutting blade down on the pipe surface.
6.2	The cutting procedure begins as soon as the cutting blade immerses into the pipe surface. While cutting make absolutely sure that the pipe cannot move and that it always lies on the rest in front and behind of the blade.
	
6.3	Continue to lower the cutting blade until the pipe is cut.
	

6.4 End of the cutting procedure

Step	Action
7 7.1	<p data-bbox="272 286 644 315">Bringing the cutting blade up</p> <p data-bbox="272 338 1289 398">After the pipe has been cut, move the cutting blade upwards by turning the crankshaft counterclockwise.</p> 
8 8.1	<p data-bbox="272 1099 635 1128">Reinstall the blade protector</p> <p data-bbox="272 1151 1406 1211">After having moved the cutting blade up far enough, reinstall the blade protector to minimize the risk of injuries.</p> 

7. Service

- After 6 to 12 months, depending on the frequency and manner of use, the tool should be checked and service by an authorised service station.
- Check the cutting blade for damages. A damaged or dull cutting blade will make the cutting procedure more difficult.
- Before using the tool remove any dirt especially from the threaded spindle. Dirt, sand or small stones can get caught in the threads and block the spindle and/or severely damage the tool. Always check for ease of movement of the threaded spindle.
- Never use excess force. If the mechanism is blocked, check for dirt or lodged foreign objects. Working with unnecessary force can damage the tool.
- Should the mechanism be difficult to move without any obvious reason, use a grease gun and lubricate the tool via the grease nipples.

8. Declaration of conformity

We declare herewith under our sole responsibility, that the product described under "Technical data" is compliant to the following standards or normative documents:

Document	Description	Edition	Classification
2006/42/EEC	Machine directive	2006	D

This declaration loses its validity as soon as changes are made to the product without consulting the manufacturer first.

Technical documentation is available at:	Achim Spsychalski-Merle, CEO PF-Schweißtechnologie GmbH Karl-Bröger-Str.10 36304 Alsfeld Germany
Place, date	Alsfeld, 01.08.2017

The declaration printed here represents only an extract. The full document can be provided to you on request.



General

**Read complete manual!
Observe fitting manufacturer's installation guide!
Follow national and international directives!**

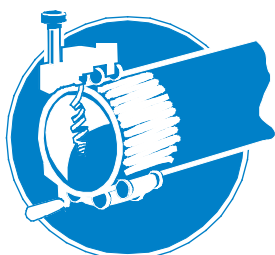

Scraping

**Remove dirt from the pipe!
Mark welding area!
Use rotational scraper tools only!**



Cleaning

**Wipe around the pipe!
Use approved cleaning agent!
Use lint-free cloths!**

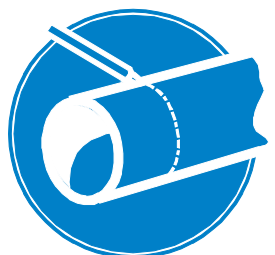

Marking

**Do not touch the cleaned welding areas!
Mark insertion depth of fitting!
Use approved markers!**

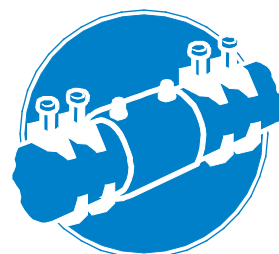

Alignment

**Use proper alignment tools!
Avoid mechanical stress on pipes and fitting!
Wait for cooling before pressurising!**

PF-Schweißtechnologie GmbH

Karl-Bröger-Straße 10

DE-36304 Alsfeld/Germany

Phone +49 6631 9652-0

E-Mail: info@pfs-gmbh.com

www.pfs-gmbh.com